

GLL PROSNK C

GALLERY Tap Range Gallery Pro Glide Professional Sink Mixer Chrome



Specification

Product Type:	Kitchen Taps
Main Construction Material:	Brass
Mount Type:	Deck
Handle Type:	Lever
Connection Inlet:	1/2" BSP Flexible Tails
Connection Outlet:	Dual-Function Handset
Number of Tap Holes:	1
Valve/Cartridge Type:	35mm Single Lever Cartridge
Plumbing System Requirements:	Suitable for high pressure systems
Minimum Dynamic Pressure (bar):	1.5 bar
Maximum Dynamic Pressure (bar):	5 bar
Maximum Hot Water Temperature °C:	65°C
Maximum Static Pressure (bar):	10 bar
Flow Type:	Dual
Isolation Included:	No

Features:

- Pull-out handset with 600mm flexible hose
- Intelligently designed spout ensures the handset rotates to the correct angle, whilst two magnets ensure the hose and handset is perfectly retracted and docked every time
- Long life ceramic cartridge for added durability and ease of use
- Metal fixing nut for added durability
- Minimum working pressure of 1.5 bar

Product Certifications:



For more products, visit our website:
<http://www.bristan.com>



Dimensions (measurements in mm)

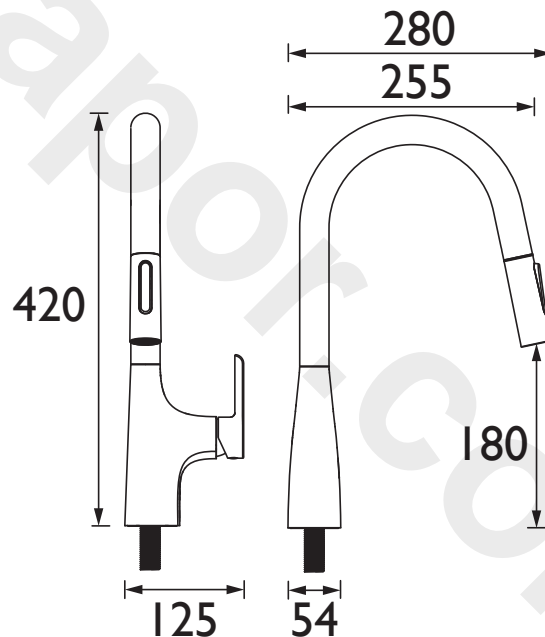

Flow Rates (l/min)

System Pressure (bar)	1.5	2	3	4	5
GLL PROSNK C (mixed)	5.2	6	7.3	8.4	9.4

TECHNICAL DATA SHEET



BRISTAN

D2